



EXTREME DUTY

Random Orbit Sander Ponceuse Orbitale Lijadoras Orbitales Aleatorias

Replacement Parts Manual
Manuel De Pièces De Rechange
Manual y Lista de Repuestos

PL1565

Description

Random orbit sanders quickly and efficiently produce swirl-free finishes on work surfaces such as sheet metal, wood and composite materials. A premium molded urethane sanding pad is also included.

Description

Les ponceuses orbitales produisent des finis sans spirales rapidement et efficacement sur les surfaces de travail tels que la tôle, le bois et les matériaux composés. Un tampon en uréthane supérieur coulé est aussi compris.

Descripción

Las lijadoras orbitales aleatorias producen, en forma rápida y eficiente, acabados libres de remolinos sobre superficies tales como láminas de metal, madera y materiales compuestos. También se incluye una almohadilla para lijar de uretano moldeado de calidad superior.

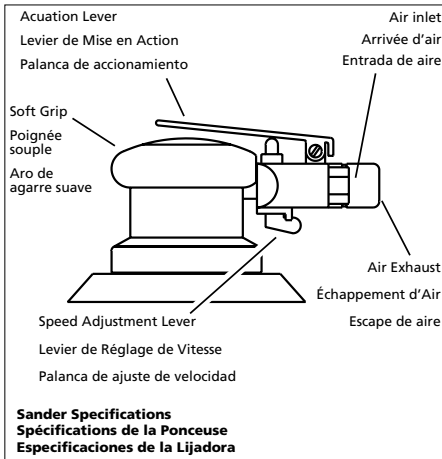

Specifications

Avg SCFM & psi	...11.6 @ 90 psig (70% usage)
Continuous SCFM	...16.6 @ 90 psig (100% usage)
Max. RPM	...10,000
Orbit Pattern	...3/16"
Controls	...Variable speed
Air Inlet	...1/4" NPT (Female)
Grip Size	...3"
Tool Weight	...2.0 lbs.
Pad Type	...5" Vinyl face, tapered edge
Pad Weight	...100 grams
Sandpaper	...PSA (pressure sen- sitive adhesive) backing

Spécifications

m ³ /min moyen et kPa	...0.33 @ 621 kPa (usage 70%)
m ³ /min continu	...0.47 @ 621 kPa (usage 100%)
tr/min Max	...10.000
Configuration orbitale	...3/16 po orbitale
Commandes	...Vitesse variable
Arrivée d'air	...1/4po NPT (Femelle)
Taille de poignée	...3 po
Poids	...0.91 kg
Type de tampon	...Face en vinyle 12,70 mm, bord en fuseau
Poids de tampon	...100 grammes
Papier de verre	...PSA (sensible à la pression auto- collant)

Especificaciones

m ³ /min promedio y bar	...0.33 @ 6,21 bar (70% de uso)
m ³ /min continuo	...0.47 @ 6,21 bar (100% de uso)
RPM Máx	...10.000
Patrón orbital	...4.8 mm (3/16")
Controles	...Velocidad variable
Admisión de aire	...6,3mm (1/4") NPT (Interior)
Tamaño del aro de agarre	...7,62 cm (3")
Peso	...0.91 kg
Tipo de almohadilla	...12,7 cm (5 pulg.), Cara de vinilo, borde cónico
Peso de la almohadilla	...100 gramos
Papel de lija	...con ASP (adhesivo sensible a la pres- ión) en la parte posterior

For Replacement Parts, call 1-800-543-6400

Pour Pièces De Rechange, appeler 1-800-543-6400

Para ordenar repuestos, sírvase llamar al concesionario más cercano a su domicilio

Please provide following information:

- Model number
- Stamped-in code
- Part description and number as shown in parts list

S'il vous plait fournir l'information suivante:

- Numéro du modèle
- Code estampé
- Description et numéro de la pièce

Address parts correspondence to:

Correspondance:
The Campbell Group
Attn: Parts Department
100 Production Drive
Harrison, OH 45030 U.S.A.

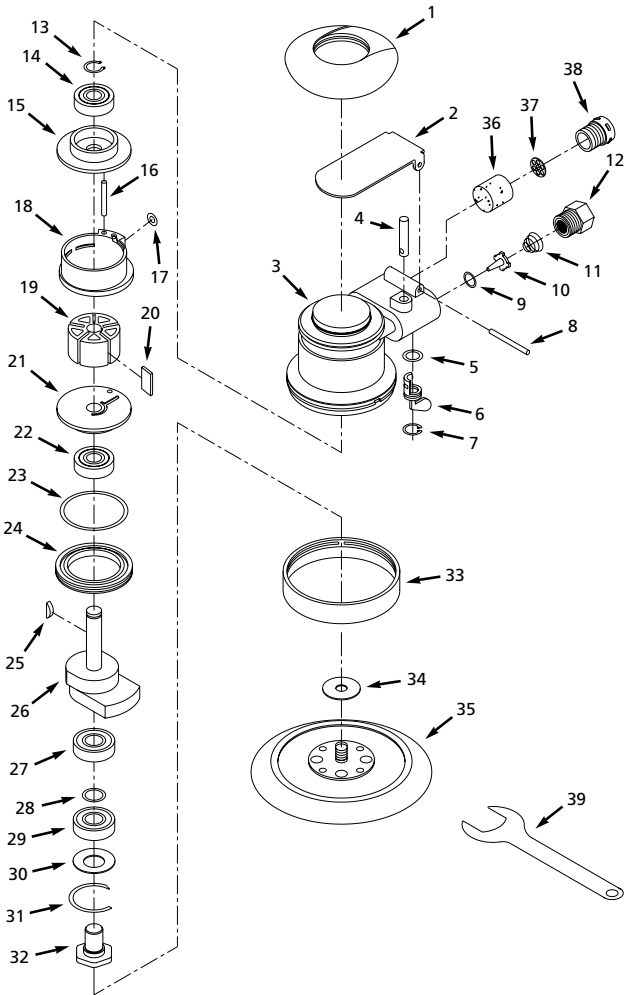

Replacement Parts List

Ref. No.	Description	Part Number	Qty.
1	Grip ring	SX111400AV	1
2	Throttle lever	■	1
3	Housing	SX111600AV	1
4	Valve stem	▲	1
5	O-ring	▲★	1
6	Speed adjustment lever	▲	1
7	Int. retaining ring	▲★	1
8	Spring pin	■★	1
9	Valve seat	▲★	1
10	Valve	▲	1
11	Spring	▲	1
12	Air inlet bushing assembly	SX112500AV	1
13	Ext. retaining ring	†★	1
14	Bearing	◇	1
15	Rear end plate	◇	1
16	Spring pin	□	1
17	O-ring	□★	1
18	Cylinder	□	1
19	Rotor	SX113200AV	1
20	Vane	†	5
21	Front end plate	○	1
22	Bearing	○	1
23	O-ring	★	1
24	Lock ring	SX113700AV	1
25	Key	★	1
26	Balancer shaft	SX113900AV	1
27	Bearing	●	1
28	Bearing spacer	●★	1

Ref. No.	Description	Part Number	Qty.
29	Sealed bearing	●	1
30	Belleville washer	●★	1
31	Retaining ring	●★	1
32	Spindle	●	1
33	Shielding skirt	SX114600AV	1
34	Spacer (included with #35)	—	1
35	Sanding pads (includes #34)		
	Tapered edge, psa	SX114800AV	1
Δ	Tapered edge, hook and loop	SX114900AV	1
Δ	Flat, psa	SX115000AV	1
Δ	Flat, hook and loop	SX115100AV	1
36	Muffler	◆	1
37	Muffler plate	◆	1
38	Exhaust bushing	◆	1
39	24mm Pad wrench	SX115600AV	1

SERVICE KITS

†	Vane kit	SX156501AV
□	Cylinder assembly	SX156502AV
◇	Rear endplate assembly	SX156503AV
○	Front endplate assembly	SX156504AV
■	Lever kit	SX156505AV
▲	Air valve and speed adjustment kit	SX156506AV
●	Spindle assembly	SX156507AV
◆	Exhaust kit	SX156508AV
★	Small parts kit	SX156509AV
(Δ)	Optional item, purchase separately	

Liste De Pièces De Rechange

N°de Réf.	Description	Numéro de Pièce	Qté.
1	Bague de fixation	SX111400AV	1
2	Lever d'obturateur	■	1
3	Carter	SX111600AV	1
4	Tige de manoeuvre	▲	1
5	Joint torique	▲★	1
6	Lever de réglage de vitesse	▲	1
7	Bague de retenue intérieure	▲★	1
8	Goupille de ressort	■★	1
9	Siège de soupape	▲★	1
10	Soupape	▲	1
11	Ressort	▲	1
12	Traversée équipée d'arrivée d'air	SX112500AV	1
13	Bague de retenue extérieure	†★	1
14	Palier	◇	1
15	Plaque d'extrémité arrière	◇	1
16	Goupille de ressort	□	1
17	Joint torique	□★	1
18	Cylindre	□	1
19	Rotor	SX113200AV	1
20	Pale	†	5
21	Plaque d'extrémité avant	○	1
22	Palier	○	1
23	Joint torique	★	1
24	Bague de blocage	SX113700AV	1
25	Clavette	★	1
26	Tige de stabilisateur	SX113900AV	1
27	Palier	●	1
28	Entretoise de palier	●★	1

N°de Réf.	Description	Numéro de Pièce	Qté.
29	Palier scellé	●	1
30	Rondelle Belleville	●★	1
31	Bague de retenue	●★	1
32	Tige de manoeuvre	●	1
33	Jupe de protection	SX114600AV	1
34	Entretoise (compris avec #35)	—	1
35	Tampons pour sabler (#34 inclus)		
	Bord en fuseau, PSA auto-collant	SX114800AV	1
Δ	Bord en fuseau, crochet et boucle	SX114900AV	1
Δ	Plat, PSA auto-collant	SX115000AV	1
Δ	Plat, crochet et boucle	SX115100AV	1
36	Silencieux	◆	1
37	Plaque de silencieux	◆	1
38	Douille d'échappement	◆	1
39	Clé pour tampon de 24 mm	SX115600AV	1

NÉCESSAIRES D'ENTRETIEN

†	Trousse de aube	SX156501AV
□	Montage de cylindre	SX156502AV
◇	Montage de plaque d'extrémité arrière	SX156503AV
○	Montage de plaque d'extrémité avant	SX156504AV
■	Nécessaire de levier	SX156505AV
▲	Nécessaire de soupape d'air et de réglage de vitesse	SX156506AV
●	Montage de tige de manoeuvre	SX156507AV
◆	Nécessaire d'échappement	SX156508AV
★	Trousse de petites pièces	SX156509AV
(Δ)	Article en option, l'acheter séparément	

